

LUBRICATE ALL SEALS WITH CLEAN HYDRAULIC OIL PRIOR TO ASSEMBLY. DO NOT USE SILICONE BASED LUBRICANTS.

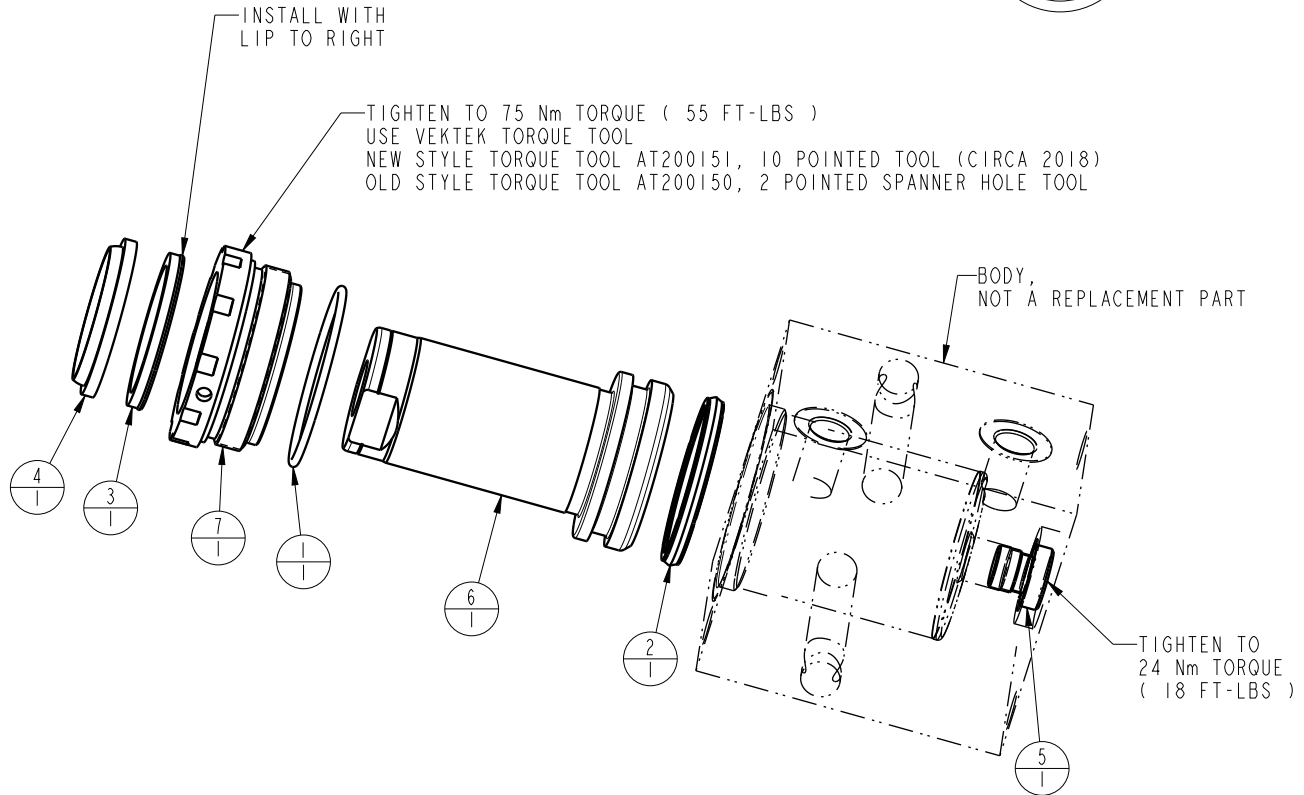

N/A	N/A	6V200214	KIT, SEAL, FKM	N/A	NOTED
N/A	N/A	46000034	KIT, SEAL, STANDARD	NOTED	N/A
7	1	82031501	GLAND, CYL, 8800 & 39.9 KN		
6	1	48011501	PISTON, CYL, 39.9 KN, 25.5 STRK		
5	1	43068004	PLUG, 1/8 BSPP		
4	1	39050020	WIPER, SNAP-IN, (1-1/8)	X	X
3	1	39011048	SEAL, LL, (1-1/8 X 1/8 X 1/8 X 1-3/8)	X	39012007
2	1	39011031	SEAL, CROWN, 1-5/16x1-1/2x5/32	X	39V11031
1	1	39001013	O-RING, (-029)	X	39012014
No.	QTY	PART No.	DESCRIPTION	Standard Seal Kit	FKM Seal Kit

PARTS LIST



VEKTEK, INC.
1334 E. SIXTH AVE. P.O. BOX 625
EMPORIA, KS. 66801 U.S.A.

ASSEMBLIES AFFECTED
42012006

PARTS LIST, ASSY, CYL, BB, 39.9KN, 25.5 STRK, DA

SIZE
A MPL2064

REV
J

FORM FEG035_PL_ASIZE, REV. B

J	4249	RELEASE	JDW	08/13/20
REV	IN ACCORDANCE WITH ECN	EFFECTIVE DATE	REVISED BY	DATE
DRW BY:	BUSH	DRAWING STATUS: Released		
DATE:	12/15/94	PRODUCTION APPROVED FOR RELEASED STATUS ONLY		

SHEET 1 OF 1